

VibWire-108 Operations

Connecting the VibWire-108 to Campbell CR200, CR800 & CR10X Loggers

Download the VibWire-108 User manual at <http://keynes-controls.com/vibwire/usermanualv103.pdf>

The following pages details how to connect the Campbell Scientific range of data loggers to the VibWire-108 family of vibrating wire sensor interfaces. Any Campbell logger can be used so long as an SDI-12, RS-485 or analogue input ports are available. The switched power supply ports available on some Campbell loggers are ideal for driving the VibWire instruments as they can be powered off between readings to minimise power supply ratings.

Operations

The simplest way to read information from the VibWire instruments into a Campbell logger is to use the SDI-12 serial network. The complete process of reading a signal from a Vibrating wire sensor to the storage within the logger is purely a digital operation. The Campbell logger acts as the SDI-12 Master and the VibWire-108 instruments as SDI-12 slave units. The standard SDI-12 commands shown within Campbell manuals are compatible to reading information from the Keynes Controls product range.

CR10X Connection

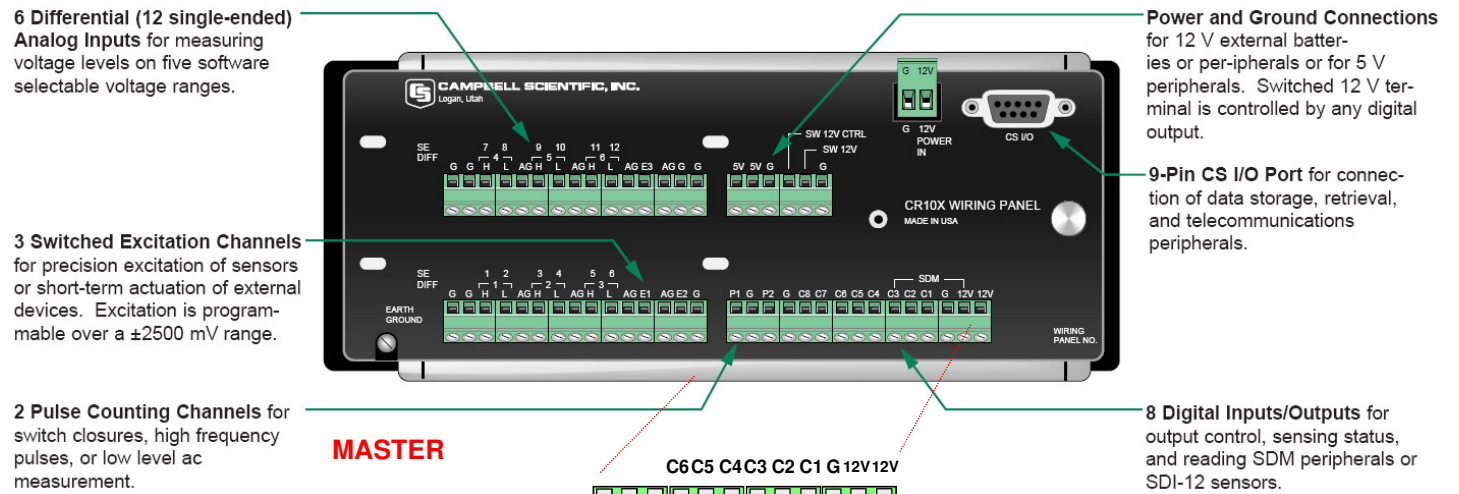

The Campbell CR10X Logger is manufactured by Campbell Scientific USA

see <http://www.campbellsci.co.uk>

SDI-12 Serial Network Connection

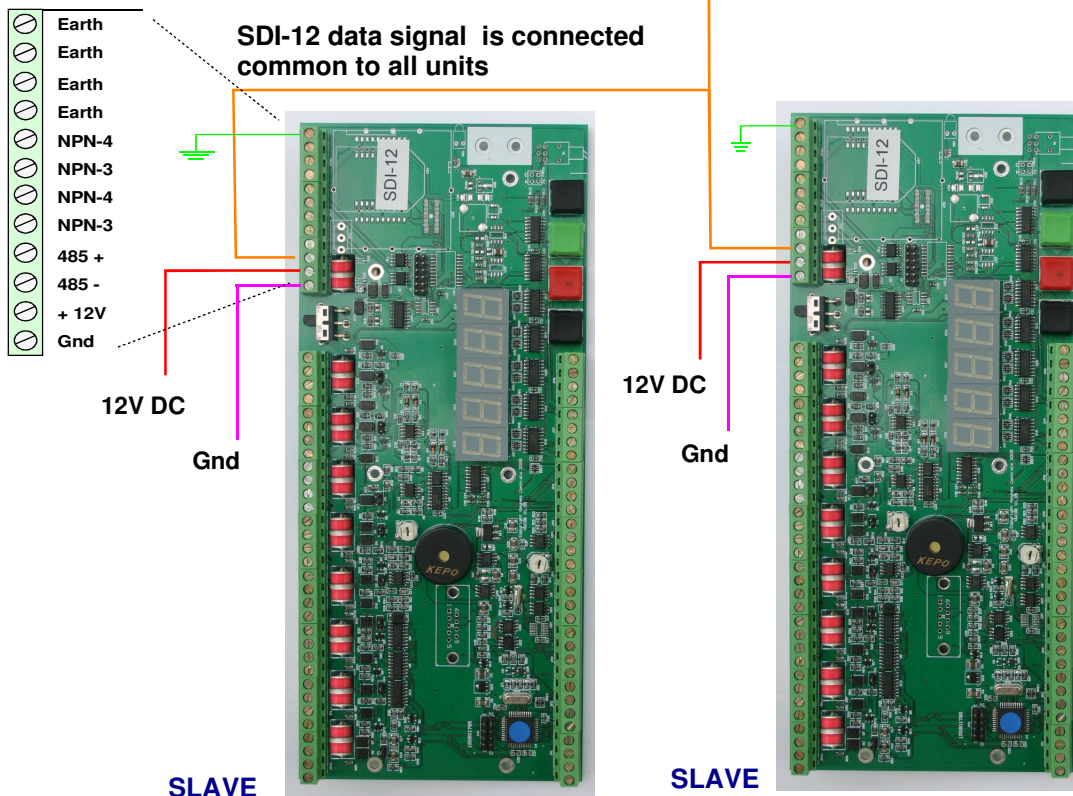

Connecting the VibWire-108 to Campbell CR800 Loggers

Operations

The CR800 & CR850 model data loggers can read information from the VibWire instruments using the SDI-12 serial network. The complete process of reading a signal from a Vibrating wire sensor to the storage within the logger is purely a digital operation. The Campbell logger acts as the SDI-12 Master and the VibWire-108 instruments as SDI-12 slave units. The standard SDI-12 commands shown within Campbell manuals are compatible to reading information from the VibWire-108 interface. Refer to the product manual for detail son reading data across the SDI-12 port.

CR800 & CR850 connected to SDI-12

All of the sensor inputs and SDI-12 port are gas discharge tube or transorb protected making the use of the VibWire-108 the desired choice for remote field applications.

Interface Deployment Options

Several methods for using the VibWire-108-SDI12 and CR800 loggers are detailed below.

Direct Connection to Logger

Using the Switched 12V output under program control the CR800 logger can power up the VibWire-108 using the internal battery as the power supply, wait for the interface to complete the desired sensor scan, read the information and then power of the unit.

Low Power Mode

Connect the VibWire-108 to a solar cell and battery backup unit. Using the internal clock within the instrument the VibWire-108 can wake up, make a scan of the sensors and wait for the CR850 to make a reading then it will power off. This method of deployment will remove the use of the logger as the power source and yet maintains low power operations.

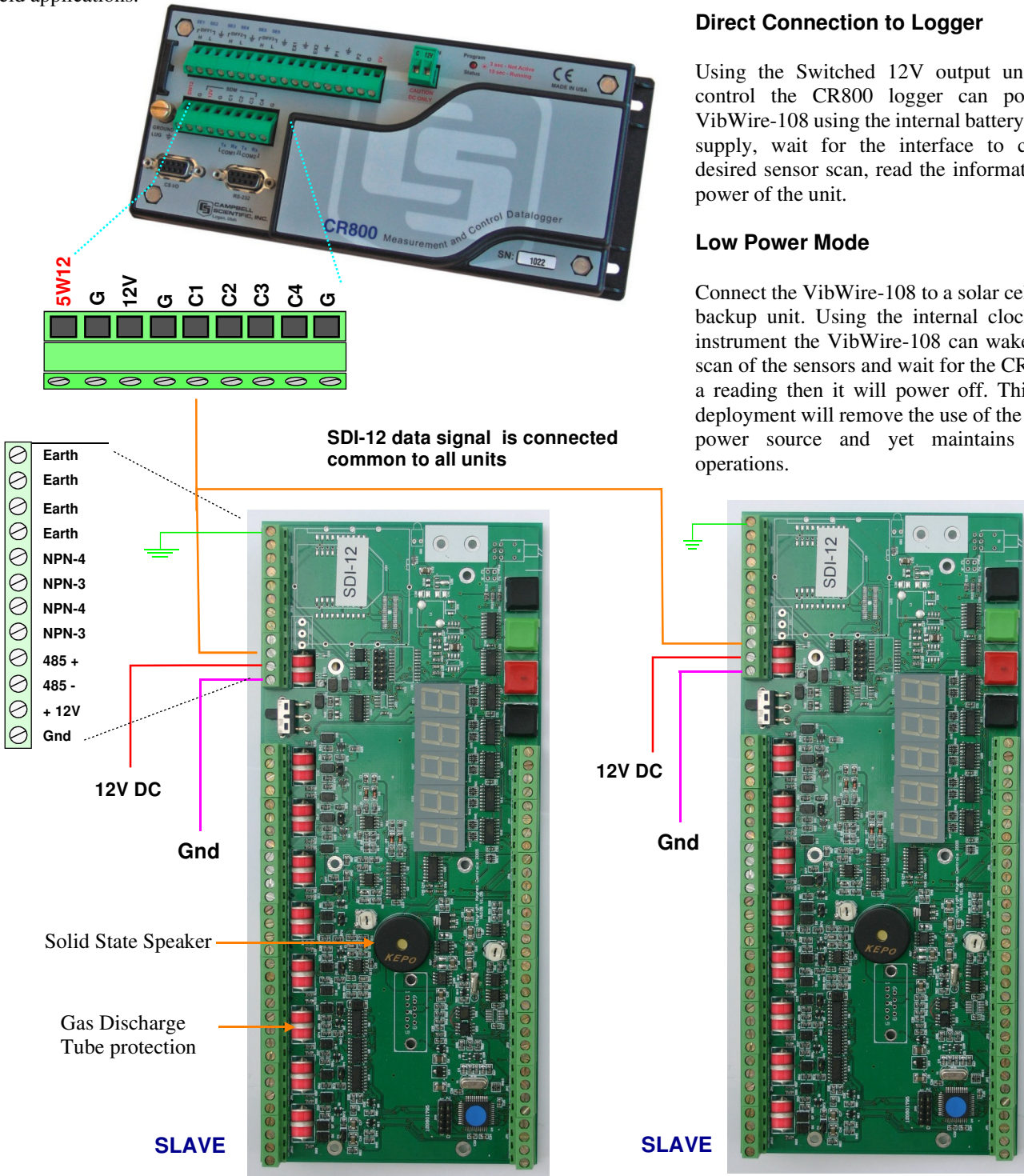

The Campbell CR800 & CR850 Loggers are manufactured by Campbell Scientific USA

Connecting the VibWire-108 to Campbell CR200 Loggers

The Campbell CR200 range of loggers can be configured to read sensor information from the VibWire-108 -SDI12 simply by using the digital SDI-12 serial communications port. The number of vibrating wire sensors to be scanned is configured within the VibWire-108 leaving the CR200 to only control the power supply and make the sample readings. All sensor inputs are gas discharge protected making the VibWire-108 an ideal partner to operate with the CR200 in the field. Simply install the sensors, power up and start recording values.

Sensor Scanning & Power Supply Options

The Campbell CR200 can be configured to use the SWBatt switched power supply option to power on the VibWire-108 as shown for SLAVE-1 below. Before this can be activated the VibWire-108 must be correctly configured to transmit data using the SDI-12 serial port. Activating the SDI-12 port on the VibWire-108 is the only configuration parameter needed to enable the instrument to operate with the CR200. The switched battery operation enables the instrument to be driven directly from the logger and powered off between readings.

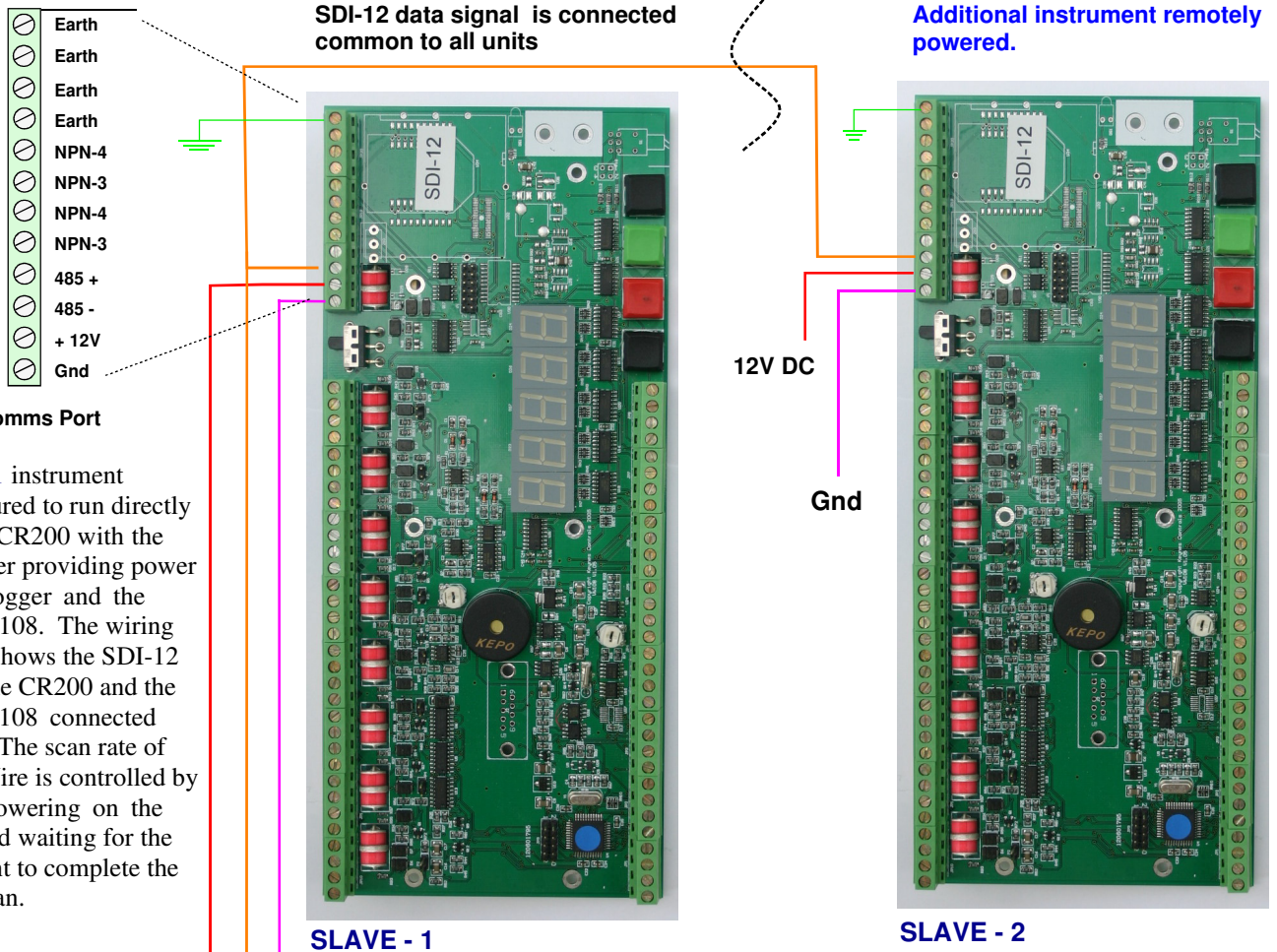

Pin-out Comms Port

SLAVE-1 instrument is configured to run directly from the CR200 with the data logger providing power for the logger and the VibWire-108. The wiring diagram shows the SDI-12 port on the CR200 and the VibWire-108 connected together. The scan rate of the VibWire is controlled by simply powering on the device and waiting for the instrument to complete the sensor scan.

SLAVE-2 is connected to the CR200 using only the SDI-12 serial port. An external 12V DC supply and Ground connection is all that is required to additional sensor channels.

Low Power Operations

Use the Switch Battery supply on the CR200 minimises the power required since the VibWire interface is only powered on when a reading is needed and then powered off in between readings.

Programming & Software

The CR200 communicates to the VibWire-108-SDI12 like any other slave device and so the software shown in the CR200 manual for SDI-12 operations is fully compatible to the instrument.

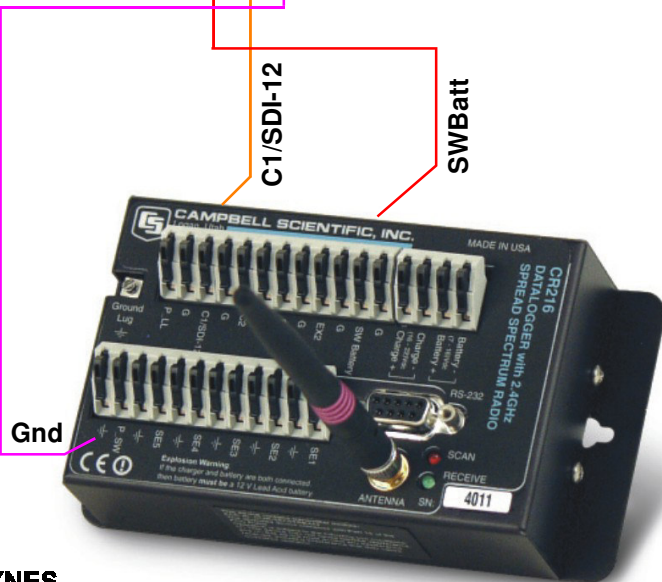

Software / Programming Cable Loggers for SDI-12 Applications

All of the Campbell Scientific range of loggers that support SDI-12 communications are programmed in the same way and have the logger acting as the SDI-master and the interface or sensor from which the data is to be read act as SDI-slaves. The information below is meant as just a summary of the commands used by the Campbell loggers for SDI-12 applications and a User should refer to the product manual for full instructions.

for further information use see <http://www.campbellsci.co.uk> or contact support@campbellsci.co.uk outside Europe support@campbellsci.com

The following information is an extract from the CR200_june2006.pdf available from Campbell Scientific manual Disk.

SDI12Recorder(Dest, OutString, Multiplier, Offset)

The SDI12Recorder instruction is used to retrieve the results from an SDI-12 sensor.

Each execution of the SDI12Recorder instruction sends an (address)M! and then an (address)D0! M! instructs the sensor to make the measurement; D0! is a request for the data. This instruction can also be used to send extended commands to the sensor, as well as variables from the data logger's public table.

Parameter & Data Type

Enter

Dest Variable or Array

The variable or variable array in which to store the results of the measurement. When requesting data from a sensor, Dest must be dimensioned large enough to store all the data that is returned or a 'variable out of range' error will result during the execution of the instruction.

If this instruction is used to send extended commands to the sensor, the Dest parameter stores the result of the command. 0 indicates the command was successful; NaN indicates the command failed.

OutString

The OutString parameter is used to specify the SDI-12 sensor's address and the command strings that will be sent to the sensor.

Values from the public table can be sent to the sensor using the following command:

```
"0XD%variable_name%!"
```

Multiple values from an array can be sent by preceding the array name with the number of values to send (e.g., "0XD%3variable%!" would send Variable(1), Variable(2), and Variable(3)).

Mult, Offset Constant, Variable, Array, or Expression

The Mult and Offset parameters are each a constant, variable, array, or expression by which to scale the results of the measurement.

VibWire-108-SDI12 with Plastic Cover



All of the Keynes Controls range of Vibrating Wire instruments are supplied on a DIN rail mount and with a protective plastic case.

Power Supply

12 V DC
at 50 mA during ping
and 50 uA in sleep mode

Opr temp - 40 to + 80 Deg C

VibWire-108 Serial Port Communications

The instructions below detail the operations to follow to operate the VibWire-108 across both the SDI-12 and RS-485 serial networks.

No sensor configuration details need be applied to the VibWire-108 when operating with the cable free transmitter, RS-485 or SDI-12 network. Simply connect the sensors to the interface as shown in Fig 2 and initiate the commands listed below.

Recommended Test

Use a single instrument only when undertaking initial measurements with a VibWire-108 on the RS-485 or SDI-12 network. This simplifies the software and will speed up the understanding of the command used to obtain data. It is very easy to test the results measured across the RS-485 and SDI-12 network with the ones shown on-board frequency display of the unit.

The results obtained across the RS-485 and SDI-12 network will be same as those shown on the display for a specified channel.

The default instrument address for a unit straight out of the box is 0

Issue command **0M!** to start measurement operations. The VibWire-108 will scan all channels

0D0! returns items of data *address ± data 4d1, ± data 4d1, ± data 4d1, ± data 4d1*

Ensure that each instrument used on a network has a unique ID number assigned within its configuration in order to correctly identify the data that is being recorded.

Real-time Frequency Display

The VibWire-108-SDI12 contains a 5 digit 7 segment display and this can be used to display the instantaneous frequency from any one of the vibrating wire sensor inputs.

The Vibrating wire sensors can be deployed a considerable distance from the interface and may well be have been embedded into a structure. To ensure that the sensors are operating correctly simply observe the sensor operating frequency and then confirm the result is within the operating range as specified by the manufacturer.

When operating in a real-time mode the instrument frequency display responds instantly to effects upon the sensor.

To use the VibWire-108 as a real-time frequency display follow the instructions below:

Assigning Real-time Frequency Display

To activate the real-time frequency display

1. Starting at



The “**BASIC**” menu item is the first menu item available after the instrument is powered on.

2. Select “**Menu In**” button

3. Use the *Up & Down* Keys to select the option



The Display above shows the option required to place Channel 0 for real-time frequency output

the other options available are:

“**Analog C0d C1d C2d C3d C4d C5d C6d C7d**” C0d = Channel 0 C7d = Channel 7

Once the “**C0d**” option is selected then the “**Menu Out**” key has to be pressed to confirm this option.

4. The VW-108 will now display the real-time sensor frequency for channel 0.



The above example shows a typical real-time frequency result .

Starting SDI-12 Network Communications

To activate the SDI-12 output port on the VibWire-108-SDI12.

1. Starting at



2. Select “Menu In” button
3. Use the Up & Down Keys to select the option “Seral”

“Analg C0d C1d C2d C3d C4d C5d C6d C7d” are the other options available

Once the “Seral” output is selected the “Menu Out” key has to be pressed to confirm this option.

4. The VW-108 will return to the display



and now the SDI-12 port for the instrument is now activated.

Examples Of Using SDI-12 Instructions

4

The following examples show how to undertake the various tasks needed to setup and make readings across the SDI-12 networks.

The SDI-12 networks only supports up to 10 instruments with address range: 0 to 9 so a single Campbell instrument can read up to 80 vibrating wire sensors using the VibWire-108 interface.

Changing the ID Number (address)

The following example demonstrates how to change the instrument ID number from the default factory setting 0 to 5.

Use the command ‘aAb’

where a = Start ID

b = Final ID

master sends: ‘0A5’

Instrument responds

5\r\n Return New Line (5 representing new ID number)

Start Measurements On Distributed Instruments Upon A Network

The following example shows how to start measurements on instruments with ID numbers 2, 7, and 9 respectively.

For this example the instruments are instructed to start readings one at a time and the network is not freed up until each instrument responds that the readings are being undertaken.

The instruments will start their measurement operations but will not send data across the network until instructed to do so.

Use the command ‘aM!’

where a = Instrument ID Number

master sends: ‘2M!’

Instrument responds
followed by

‘20608\r\n’
‘2\r\n’

indicated readings available after 60 secs
when the measurement is completed

7M!

‘70608\r\n’
‘7\r\n’

9M!

‘90608\r\n’
‘9\r\n’

Note. For this command the RS-485 network will not become available until each instrument completes its measurement cycle.

Instrument Identifier

Each instrument deployed on the SDI-12 multi-drop network must have a unique instrument identifier set in order to identify specific instrument on the network. For the SDI-12 network this identifier is 0-9.

See below for details on setting the ID number.

Table Of Commands

The following commands are all those supported by the VibWire-108-SDI12 for use on the SDI-12 and 485 multi-drop serial networks.

See <http://www.keynes-controls.com/vibwire/usermanualv103.pdf>

for additional information on how to program and use the VibWire-108 range of interfaces

Comm Port Settings - SDI-12 & RS485 Network

Communication ports Settings for SDI-12 & RS485 network.

1200 baud 8 bit no parity

Description	Master / Campbell Logger Units	VibWire-108 Response
Acknowledge active	a!	a\r\n
Send ID: provided to complement SDI-12 protocol	a!	a13KEYNESCOVibWire-1080001\r\n
Address query identifies instrument address and commonly used on single instrument operations only.	?! Used to make command set SDI-12 compatible	a\r\n Part Description assigned by Keynes Where a = number 0 - 9 for SDI-12 0-9 letters a - z for RS485 A - Z
change Address: used to change instrument address from default to new one for network operations	aAb! a = initial address b = new address	b\r\n a : b = number 0 - 9 or a - z
Start Measurement instruct an instrument to make measurement	aM! a = address of instrument	a0608\r\n instrument with address a returns 8 x vibwire & 8 x temp after 60 seconds
Concurrent measurement: Used for polling multiple instruments on a network to start to make readings. This command frees RS-485 bus for other devices	aC! start measurement instrument address a	a06016\r\n initial response only after receipt of instruct and no response when data ready to be sent.
Send data data returned aND! = Vib + Vib + Therm + Therm and has same format for each command	aD0! aD1! aD2! or aD3! aD0! = channel 0 and 3 VibWire Sens aD1! = channel 4 and 7 VibWire Sens aD2! = channel 0 and 3 Therm/analog aD3! = channel 4 and 7 Therm/analog	+xxxx.x+xxxx.x+xxxx.x+xxxx.x\r\n

Additional Information

- 1 Strain gauge data is given as frequency in units (Hz)
- 2 Temperature data is given in millivolts (0000.0 to 2500.0)

The RS-485 commands are almost identical in their format and use to those used on an SDI-12 network.

Reading Values From The VibWire-108-SDI

No matter which instruction is used 'aM!' or 'aC!' to initiate measurement operations for the VibWire-108 has to be instructed to send data when it becomes available. It takes the instrument 60 seconds to make sensor values available after being instructed to make a measurement. The **vibrating wire readings** are in **Units Hz**. The **Temp/Current loop** input are in **Units mV**.

Use the command:	'aD0!'	--	Vibrating Wire inputs 0 - 3
	'aD1!'	--	Vibrating Wire inputs 4 - 7
	'aD2!'	--	Temp/current loop inputs 0 - 3 (values in mV)
	'aD3!'	--	Temp/current loop inputs 4 - 7 (values in mV)

Instrument responds: 'a+xxxx.x+xxxx.x+xxxx.x+xxxx.x\r\n' xxxx.x is the format of the number returned - 1 decimal place